

# SPECIFICATION

Product Name: Super Low Power CO<sub>2</sub> Sensor Module

Item No.: CM1106SL-NS

Version: V0.4

Date: March 4, 2021

# Revision

No.	Version	Content	Date
1	V0.1	First Edition	2020.12.07
2	V0.2	Update description of IIC protocol	2021.02.07
3	V0.3	Update description of IIC protocol	2021.03.01
4	V0.4	Update specification and register of IIC protocol	2021.03.04

# Super Low Power NDIR CO<sub>2</sub> Sensor Module

CM1106SL-NS



## Applications

- HVAC industry
- Detecting units with battery operation
- Portable instruments

## Description

CM1106SL-NS is super low power consumption, high performance NDIR battery-powered CO<sub>2</sub> sensor, which can be used to detect CO<sub>2</sub> concentration of indoor air by adopting advanced non-dispersive infrared (NDIR) technology. It is ideally suited for HVAC industry, detecting units with battery operation, portable instruments, etc.

## Features

- NDIR technology with independent intellectual property
- Super low power consumption
- High accuracy, long-term stability, long life (>15 years)
- Temperature calibration within whole measurement range
- Auto-calibration, no need of maintenance
- Small size and compact structure, easy to install
- Wide supply voltage range enables variety of battery options.
- Adjustable measurement cycle by host
- ABC setting by host

## Working Principle

The main components of an NDIR CO<sub>2</sub> sensor are an infrared source, a sample chamber, a filter and an infrared detector. The infrared light is directed by the infrared source passing through the gas chamber towards the detector.

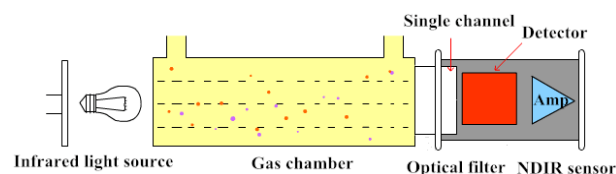

CO<sub>2</sub> molecules inside the gas chamber will only absorb a specific wavelength of the light. The filter allows only the specific wavelength corresponded to pass through it. The detector measures the intensity of infrared light that is related to the intensity of CO<sub>2</sub> and can be described through the Lambert-Beer's Law. The change in sensor signal reflects the change in gas concentration.

## CM1106SL-NS Super Low Power NDIR CO<sub>2</sub> Sensor Specification

Target gas	Carbon dioxide (CO <sub>2</sub> )
Operating principle	Non-dispersive infrared (NDIR)
Measurement range	0-5000ppm (Note 1)
Working temperature	-10°C ~ 50°C
Working humidity	0-95%RH (non-condensing)
Storage temperature	-30°C ~ 70°C
Storage humidity	0-95%RH (non-condensing)
Accuracy	± (50ppm+5% of reading) (Note 2) ± (50ppm+3% of reading) (Note 3)
Air pressure dependency	1% of reading / kPa @80-106KPa (sensor is calibrated at 101KPa)
Power supply	DC 3.3V-5.5V
Average working current	60uA (1 minute as measurement cycle) 30uA (2 minutes as measurement cycle) 12uA (5 minutes as measurement cycle)(Note 4)
Measurement Setting	Default: single measurement mode (working mode A), reading output is without moving average(Adjustable by host)(Note 5)
Dimensions	33.5x19.7x9.1mm
Weight	5g
Signal output	UART_TTL/I <sup>2</sup> C
Life span	≥15 years

**Note 1:** Sensor is designed to measure in the range 0~5000ppm. Nevertheless, exposure to concentrations below 400ppm may result in incorrect operation of ABC algorithm and shall be avoided for model with ABC ON.

**Note 2:** In normal IAQ applications, accuracy is defined with 10°C-35°C, 0-85%RH. ±(50ppm+5% of reading) could be achieved under continuous power supply mode, with 4s as working cycle and moving average based on 24 data.

**Note 3:** In normal IAQ applications, accuracy is defined with 10°C-35°C, 0-85%RH. When the sensor is under single measurement mode (controlled power supply by host), the sensor reading output is without moving average. The defined accuracy ±(50ppm+3% of reading) is based on data moving average ≥5 and range of 400~2000ppm.

**Note 4:** See Figure 4 Average Current for more information under different working cycle.

**Note 5:** See more details in Sensor Working Mode. There are two working modes, working mode A and working mode B. Working mode A is single measurement mode (controlled power supply by host), while working mode B is continuous measurement mode. Default is working mode A. Command to set working A or B is defined in UART protocol.

## Dimensions and Connector

### 1. Dimensions (Unit mm, tolerance $\pm 0.2$ mm)

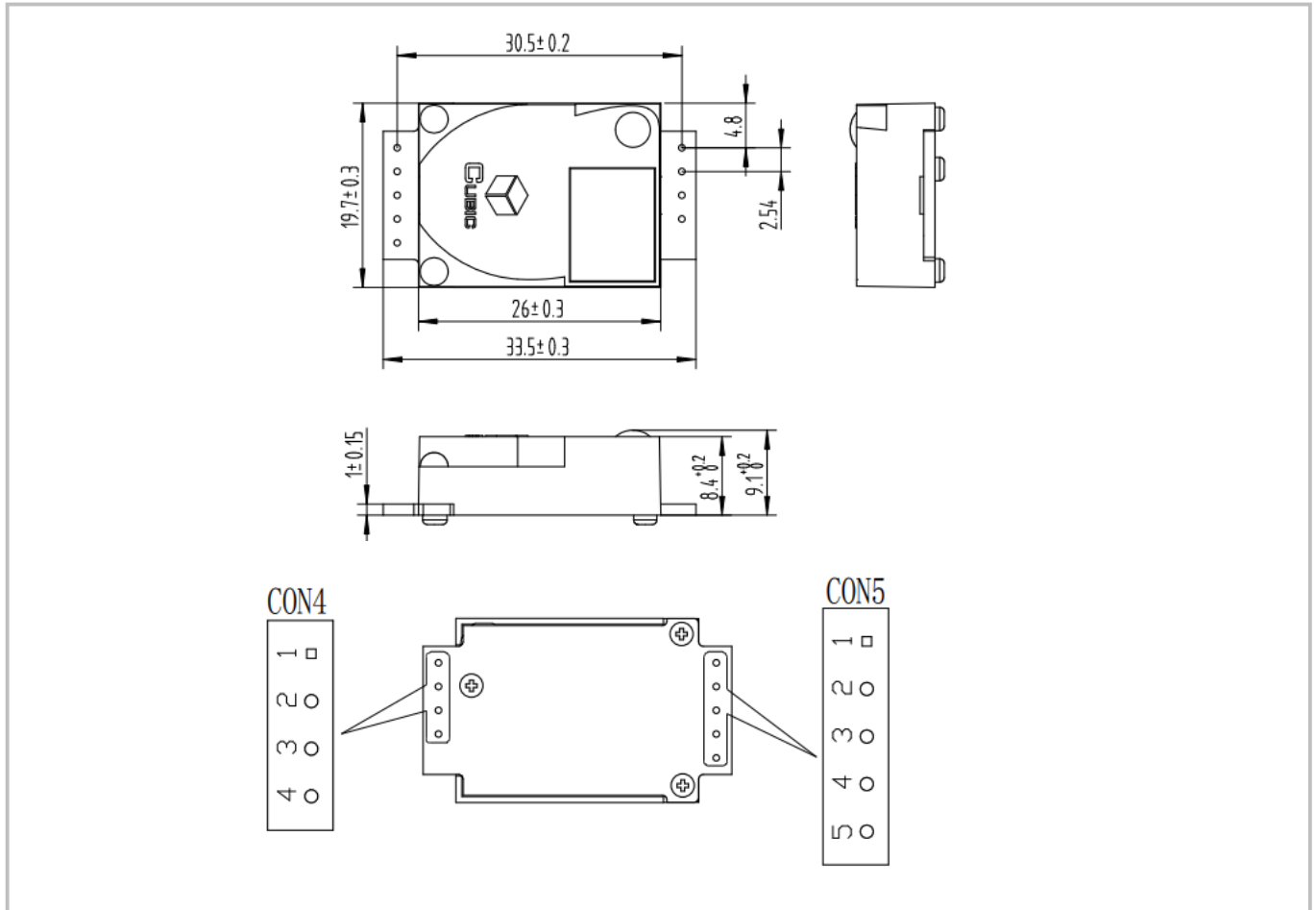

Figure 1

### 2. I/O Connector Pin out

CON5			CON4		
Pin	Name	Description	Pin	Name	Description
1	GND	Power supply input (GND)	1	EN	Power input enable (normal power supply at high power level, power off at low power level)
2	VBB	MCU power supply input (3.3-5.5V)	2	DVCC	Power supply output (2.8V)
3	VDDIO	Communication supply input	3	RDY	To indicate the sensor data is ready, and the host could communicate (2.8V).
4	RX/SDA	UART-RX/I <sup>2</sup> C-SDA	4	COMSEL	Communication swift, high level or floating for UART, low level for IIC
5	TX/SCL	UART-TX/I <sup>2</sup> C-SCL			

### 3. The Function of PIN

Pin	Function
VBB	Sensor power supply pin (3.3-5.5V)
EN	Sensor power supply switch pin (2.8-5.5V)

### 4. The explanation of Pin working

VBB Status	EN Status	Sensor Status
0	L	No Working
3.3-5.5V	L	No Working
0	H	No Working
3.3-5.5V	H	Working

### Reference Circuit

#### Application 1: UART\_TTL serial port output (Continuous Measurement Mode)

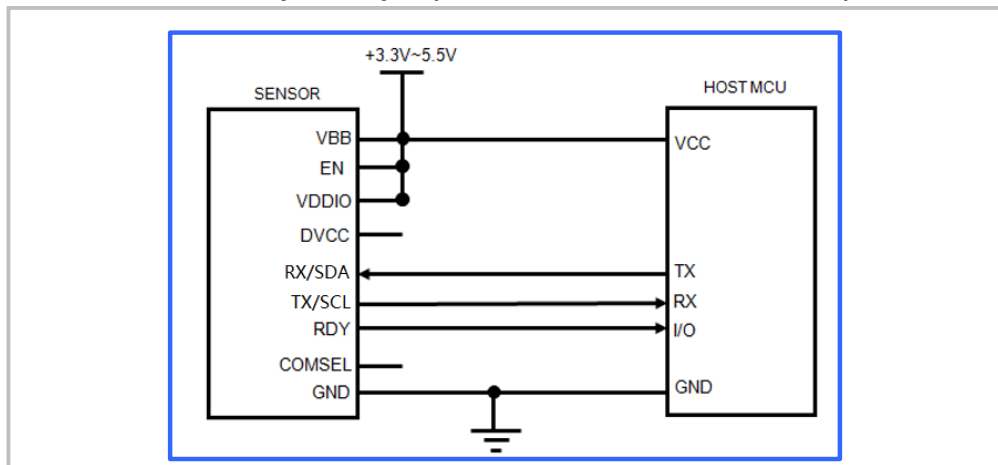

Figure 2

#### Application 2: UART\_TTL serial port output (Single Measurement Mode)

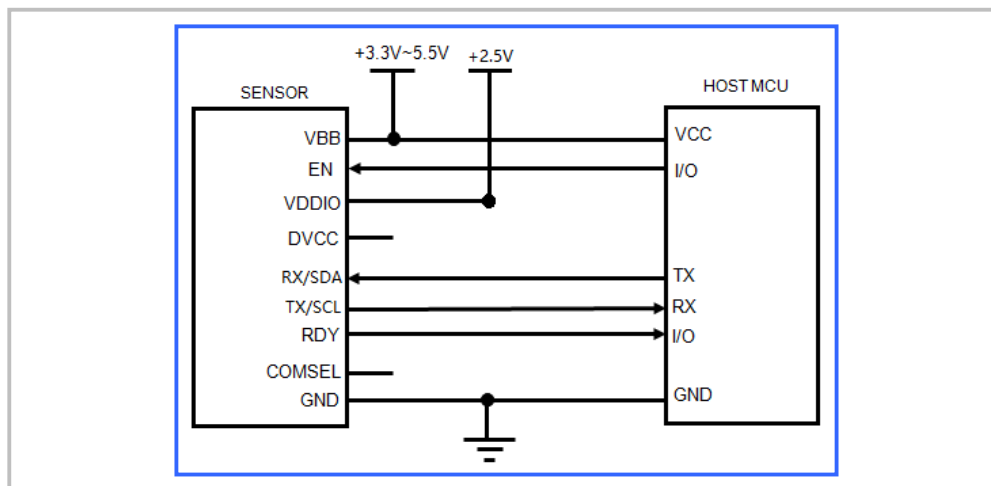

Figure 3

### Application 3: I<sup>2</sup>C serial port output (Continuous Measurement Mode)

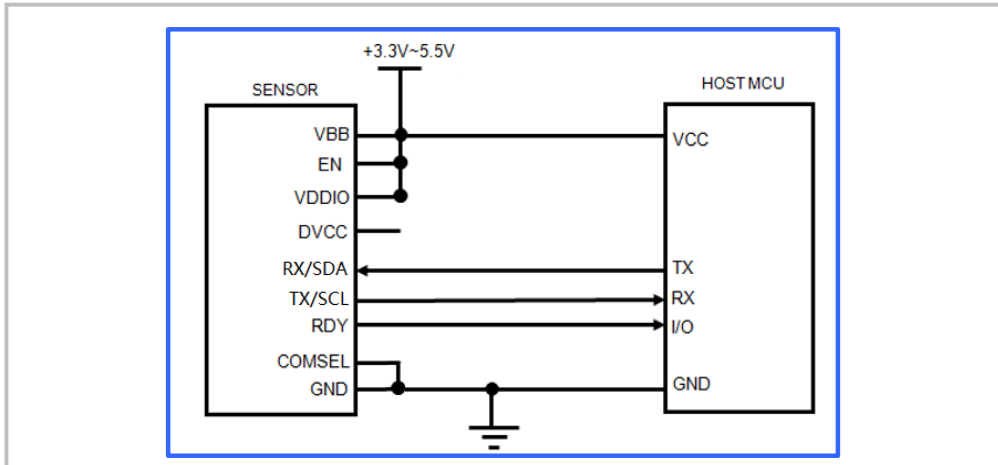

Figure 4

### Application 4: I<sup>2</sup>C serial port output (Single Measurement Mode)

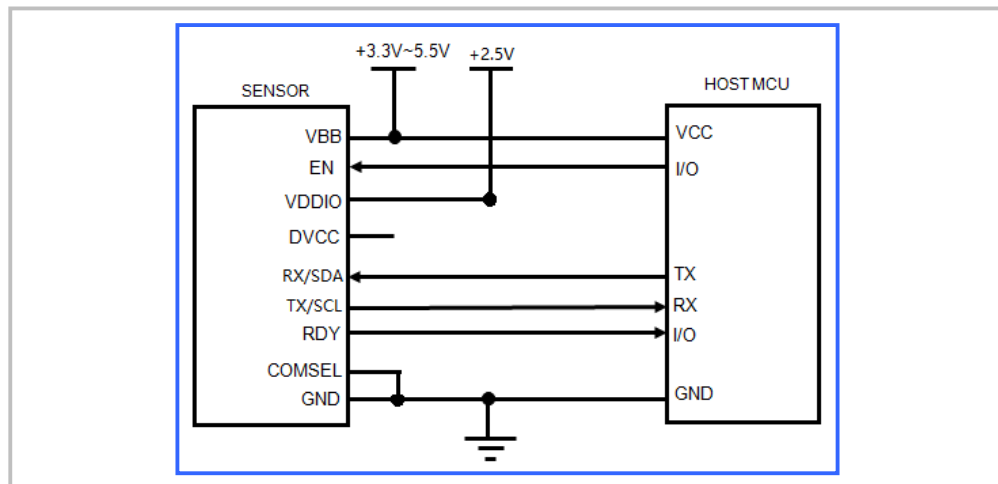

Figure 5

Note: electrical level of communication pins are the same as VDDIO pin.

## Power Consumption Chart

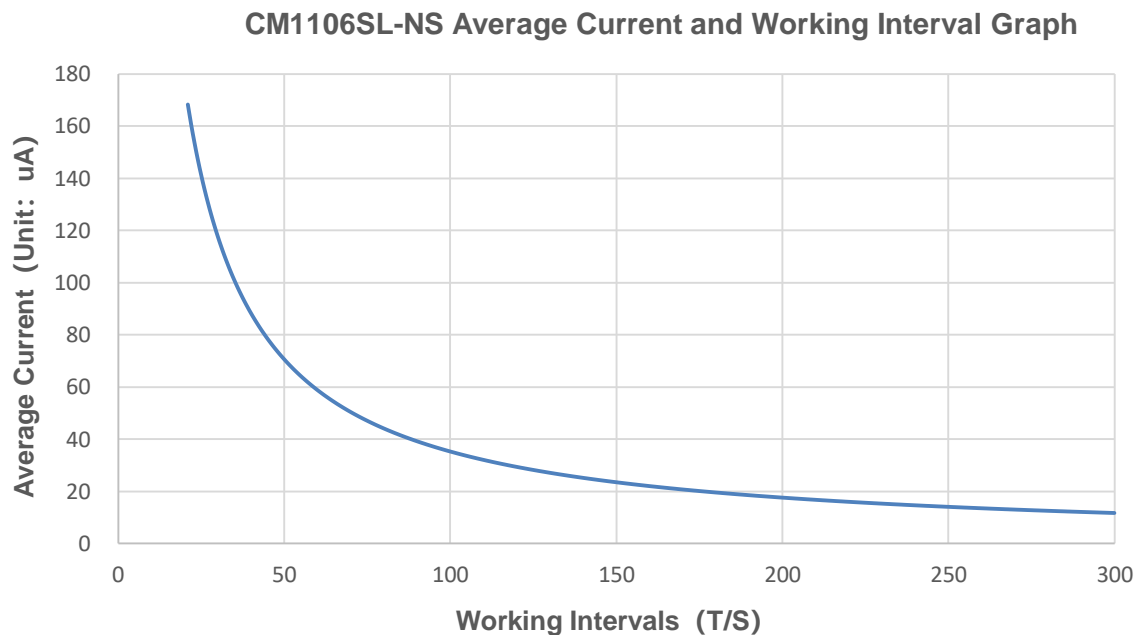

Figure 6

Blue Curve: light source work once in setting working intervals (T), every time work for 100ms.

The Graph shows the average current of CM1106SL-NS under single measurement mode (Working Mode A). To get lower working current under the same scenario, Cubic could offer sensor type with 100ms working mode for light source. Under this mode, the average working current is 30uA @ two minutes' working interval. For more information, please contact Cubic.



## Working Sequential Chart (working mode A)

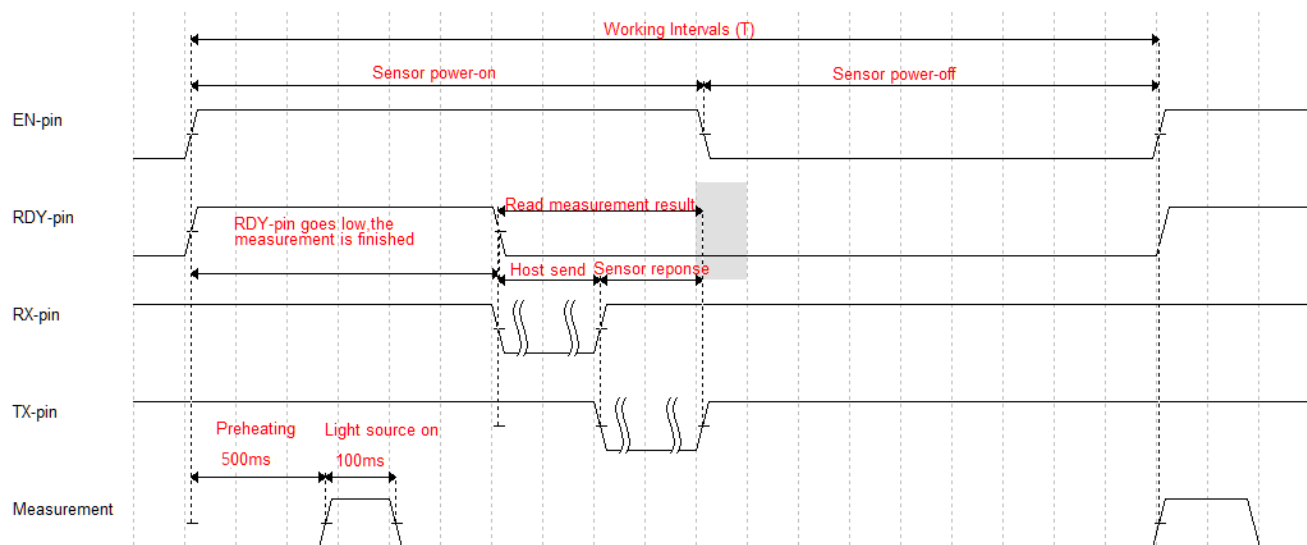

Figure 7

### 1. Explanation of working sequential chart

The working mode of CM1106SL-NS is host-slave mode: CM1106SL-NS is a slave and it begins to work after getting EN and VBB pin high level and getting power from the host. After powering on for 500ms, the light source flashes for 100ms, and then MCU of CM1106SL-NS starts a calculation on measured CO<sub>2</sub> concentration, the calculation take 100ms, consider 30ms for communication, so in total one circle working time is around 730ms. Then the host could communicate with CM1106SL-NS when the RDY pin goes low level. After communication, the host will put EN pin to low level and the CM1106SL-NS is powered off and stops working.

### 2. Explanation of working mode

Cubic Super Low Power NDIR CO<sub>2</sub> Sensor CM1106SL-NS supports two working modes for measurement of CO<sub>2</sub> concentration: single measurement mode (working mode A) and continuous measurement mode (working mode B).

#### Working mode A, single measurement mode

When in single measurement mode, the sensor works by waiting for the hosts command to measure. The host need to send a command sequence to trigger each measurement. After each measurement, EN pin need to be set to low power level. The reading output from the sensor is without moving average. The host could make moving average to get higher stability and accuracy.

#### Working mode B, continuous measurement mode

When in continuous measurement mode, the sensor works at regular intervals (default setting 2 minutes). The host can read measurement after each measurement and does not need to send any command to trigger measurements. The host could set working intervals and set moving average to get better stability.

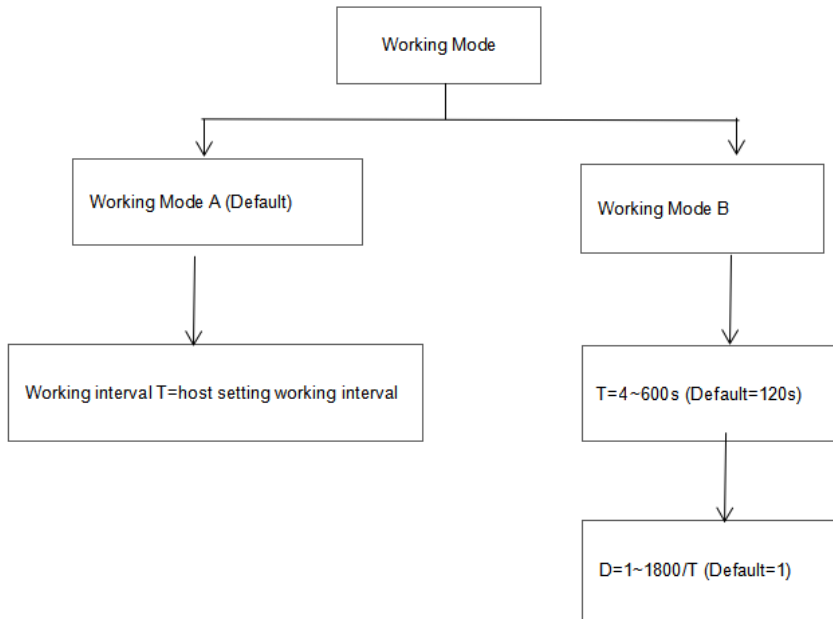

1. CM1106SL-NS is with default single measurement mode (working mode A).

Under this working mode, the working interval  $T$  = host setting working interval, the sensor works only one time during a working interval. There is no data moving average (the moving average data  $D=1$ ).

2. When host send command to activate working mode B, the sensor will enter continuous measurement mode. The host could set Working Interval  $[T]$  \* and Data Moving Average  $[D]$  \*. Setting command is in UART protocol. The default working interval is 2 minutes.

$[T]$  = Working Interval       $[D]$  = Data Moving Average  $[D]$ , maximum value is 120.

## Description of Calibration

CM1106SL-NS can support auto baseline calibration function (Auto Calibration is closed by default), the user could open the Auto Calibration function by command in protocol.

### Auto Calibration:

Rough installing and influence of transportation might result in a reducing of sensor reading accuracy and baseline drift, sensor will correct the drift by the built-in self-correcting logic.

#### 1. Continuous Measurement Mode

When the host sends command to activate working mode B, the sensor will enter continuous measurement mode. Powering on the sensor for 7 days (7 days by default) continuously, it will record the lowest  $\text{CO}_2$  concentration measurement value during the 7 days, which will be regarded as baseline (400ppm) when sensor do auto calibration after the 7 days working.

Remark: The sensor is with Auto Calibration closed by default.

## 2. Single Measurement Mode

When the host sends command to activate working mode A, the sensor will enter single measurement mode and power supply interval will be controlled by the host under mode A.

-If the power supply interval is longer than 30mins, after each time measuring, the host need to send a measuring data back to the sensor to make the sensor store this data as Auto Calibration database.

-if the power supply interval is less than 30mins, then during every 30mins working period, only the last measuring data need to be sent from the host to the sensor as an ABC calibration

(About how the host sends the data back to sensor, please refer to the communication protocol 4.9).

When the storing data reaches to calibration cycle\*48 times (default of calibration cycle is 7 days, so in single measurement mode the sensor will calibrate after  $7*48=336$  times measuring), it will invoke the lowest CO<sub>2</sub> concentration measurement from the storing data, which will be regarded as baseline (400ppm) by the sensor and implement auto calibration.

### Note:

1. If the sensor works in continuous measurement mode, please ensure the sensor is powered on during the complete one ABC working cycle, otherwise it cannot trigger the calibration.
2. In single measurement mode, CM1106SL-NS supports power-off storage, even if the power is off, the stored data is still retained, when the storing data reaches to calibration cycle\*48 times, the sensor will implement auto calibration.
3. In order to ensure the reading accuracy after auto calibration, please make sure the working environment of sensor can reach the outdoor fresh air level, that is to say, the CO<sub>2</sub> concentration of sensor can reduce to the outdoor air level (400ppm) during the 7 days.
4. Please contact with Cubic for more detailed auto calibration strategy.
5. If auto calibration environment cannot be ensured, then regular manual calibration is recommended, please refer to the communication protocol 4.2, implement calibration and set the CO<sub>2</sub> concentration as 400ppm under fresh air environment.

## Product Installation

1. In order to ensure airflow diffusion into the sensor inner, make sure the minimum distance between the area of waterproof filter and the other components is 1.5 mm, otherwise, quick response time of the sensor will be effected.

Reference as below:

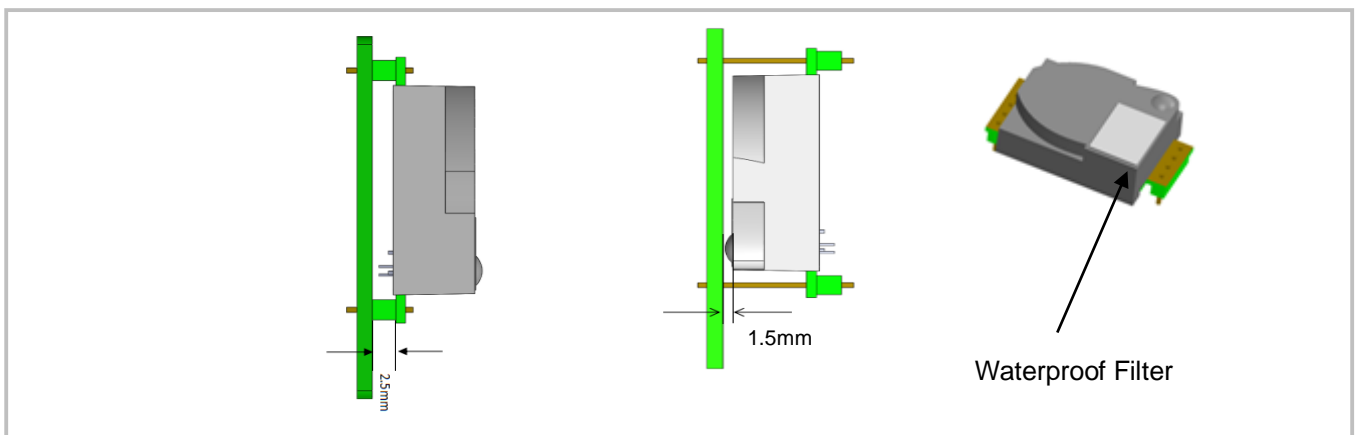

Figure 8

2. To avoid the influence of stress on sensor, please soldering by hand as much as possible when mounting the

sensor to the PCB.

**Reference as below:**

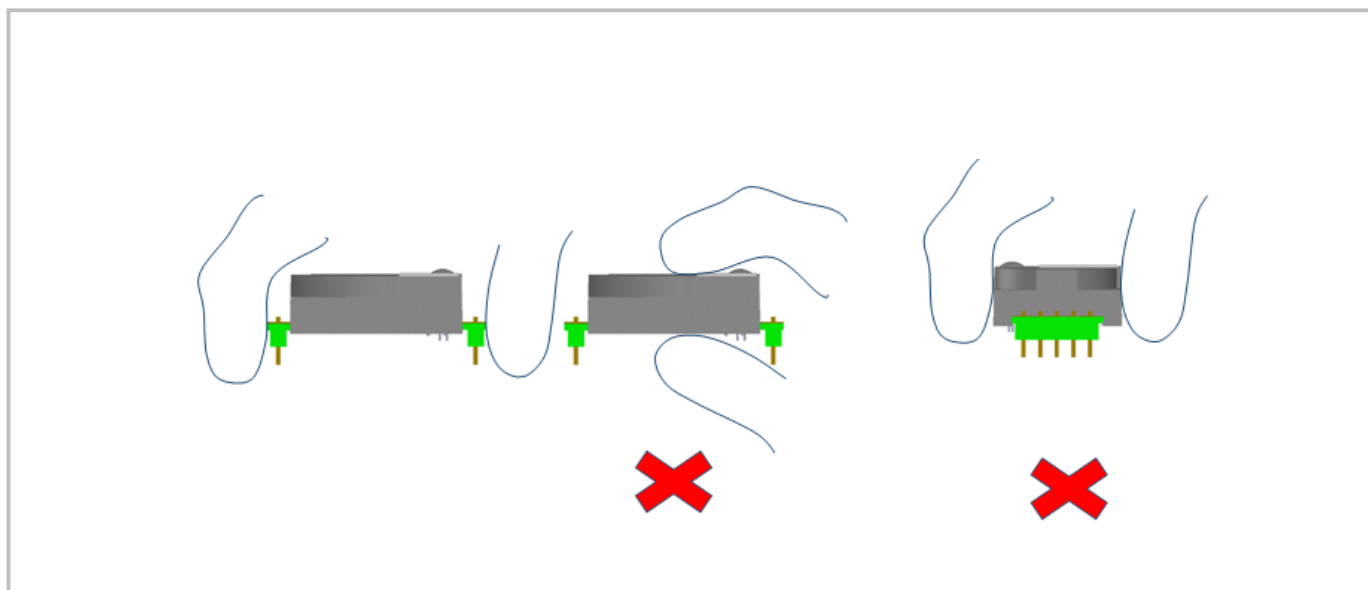

Figure 9

# UART Communication Protocol

1. CM1106SL-NS supports UART communication protocol.
2. To meet the requirements from more designers, CM1106SL-NS is with two sets of UART communication protocol. Below information is one of the UART communication protocol (Protocol Version 1). If it is not suitable for designer to integrate, please contact [info@gassensor.com.cn](mailto:info@gassensor.com.cn) to request the other UART communication protocol.
3. Customized communication protocol is also available, for more details, please contact Cubic by [info@gassensor.com.cn](mailto:info@gassensor.com.cn).

## 1. General Statement

- 1). The data in this protocol is all hexadecimal data. For example, "46" for decimal [70].
- 2). Baud rate: 9600, Data Bits: 8, Stop Bits: 1, Parity: No, Flow Control: No.
- 3). [x x] for single-byte data (unsigned, 0-255); [x x] for double data (signed, -32768~+32767), high byte is in front of low byte. It is remark after "——".
- 4). All data is an integer and may have a (100, 10, 1)-fold correspondence with the actual display data (related to the specific instrument).
- 5). Sensor operation remains after power off

## 2. Format of Serial Communication Protocol

Sending format of test software:

Start Symbol	Length	Command	Data1	...	Data n.	Check Sum
HEAD	LEN	CMD	DATA1	...	Data	CS
11H	XXH	XXH	XXH	...	XXH	XXH

Detail description on protocol format:

Protocol Format	Description
Start Symbol	Sending by test software is fixed as [11H], module response is fixed as [16H]
Length	Length of frame bytes= data length +1 (including CMD+DATA)
Command	Command
Data	Data of writing or reading, length is not fixed
Check Sum	Cumulative sum of data = 256-(HEAD+LEN+CMD+DATA)%256

### 3. Command Table of Serial Protocol

Item No.	Function Name	Command
1	Read measured result of CO <sub>2</sub>	0x01
2	Calibration of CO <sub>2</sub> concentration	0x03
3	ABC parameter check	0x0F
4	ABC parameter set	0x10
5	Read software version	0x1E
6	Read the serial number of the sensor	0x1F
7	Set /check sensor measurement period and number of smoothing data	0x50
8	Set / check sensor working status	0x51
9	Sensor ABC calibration data store	0x11

### 4. Detail Description of UART Protocol

#### 4.1 Read Measured Result of CO<sub>2</sub>

**Send:** 11 01 01 ED

**Response:** [ACK] 05 01 DF1- DF4 [CS]

**Function:** Read measured result of CO<sub>2</sub> (Unit: ppm)

**Note:**

CO<sub>2</sub> measured result = DF1\*256+DF2

DF3, DF4 is reserved

**Example:**

**Response:** 16 05 01 02 58 00 00 8A

**Explanation:**

Hex is converted to decimal: 02 is 02; 58 is 88

CO<sub>2</sub> concentration = 02\*256+88 = 600ppm

#### 4.2 Calibration of CO<sub>2</sub> Concentration

**Send:** 11 03 03 [DF0] [DF1] [CS]

**Response:** [ACK] 01 03 [CS]

**Function:** Calibration of CO<sub>2</sub> concentration

**Note:**

1. Calibration target value = DF1\*256+DF2 Unit: PPM, range (400-1500ppm)

2. Before calibration, please make sure CO<sub>2</sub> concentration in current ambient is calibration target value. Keeping this CO<sub>2</sub> concentration for two 2 minutes, and then began calibration.

3. Calibration command shall be sent AFTER at least 60s power on (VBB connected and EN pin in high level continuously), otherwise the sensor will not implement calibration to target concentration.

**Example:**

When need to calibrate CO<sub>2</sub> concentration of the sensor to 600ppm, send command:11 03 03 02 58 8F

Hex is converted to decimal: 02 is 02; 58 is 88, CO<sub>2</sub> concentration = 02\*256+88 = 600ppm

### 4.3 ABC Parameter Check

**Send:** 11 01 0F DF

**Response:** [ACK] 07 0F [DF1] [DF2] [DF3] [DF4] [DF5] [DF6] [CS]

**Function:** Sensor ABC parameter check

**Example:**

**Send:** 11 01 0F DF

**Response:** 16 07 0F 64 02 07 01 90 64 72

### 4.4 Open/Close ABC and Set ABC Parameter

**Send:** 11 07 10 [DF1][DF2][DF3][DF4][DF5][DF6][CS]

**Response:** 16 01 10 D9

**Function:** Sensor ABC parameter set

**Explanation:**

DF1: reserved, default 100 (0x64)

DF2: open/close auto calibration (0: open; 2: close, the default is close)

DF3: calibration cycle (1-10 optional, 7days is default)

DF4 and DF5: The high and low baseline of calibration. (2 bytes), baseline of calibration= $DF4*256+DF5$

DF6: reserved, default is 100 (0x64)

Note: The default baseline of calibration is 400ppm, hex is converted to decimal: 01 is 01 and 90 is 144, so DF4=01 and DF5=90 by default.

#### 4.4.1 Open ABC and Set Calibration Cycle

**Send:** 11 07 10 64 00 07 01 90 64 78

**Response:** 16 01 10 D9

#### 4.4.2 Close ABC

**Send:** 11 07 10 64 02 07 01 90 64 76

**Response:** 16 01 10 D9

### 4.5 Read Software Version

**Send:** 11 01 1E D0

**Response:** [ACK] 0C 1E [CH1].....[CH11] [CS]

**Function:** Read software version

**Note:** Input software version number: [CHx] stand for software version by ASCII code.

**Example:**

When the sensor version is V0.04SL-N2, response data as follows:

16 0C 1E 56 30 2E 30 34 53 4C 2D 4E 32 00 5C

**Note:** When hexadecimal 20 is converted to ASCII code, the ASCII code is the blank space.

### 4.6 Read the Serial Number of the Sensor

**Send:** 11 01 1F CF

**Respond:** [ACK] 0B 1F (SN1) (SN2) (SN3) (SN4) (SN5) [CS]

**Function:** Read the serial number of the sensor

**Note:** Output the serial number of the sensor. SNn is from 0 to 9999. The 20 bit number is formed by five integers.

**Example:**

**Send:** 11 01 1F CF

**Response:** 16 0B 1F 00 00 02 11 03 8C 0A D3 00 08 39

Sensor serial number: 00000529090827710008

#### 4.7 Set / Check Measurement Period and Number of Smoothed Data

**Set:**

Send: 11 04 50 [DF1] [DF2] [DF3] [CS]

Response: 16 01 50 [CS]

**Check:**

Send: 11 01 50 [CS]

Response: 16 04 50 [DF1] [DF2] [DF3] [CS]

**Description:**

Measurement period (s) period = DF1 \* 256 + DF2, unit s (range: 1s ~ 10min)

Number of smoothed data = DF3

**Example:**

Set the sensor working intervals as 2 min and the number of smooth data as 15

Send: 11 04 50 00 78 0F 14

Note: The smoothing time is no longer than 30min. If the sensor measurement period is set to 2min, the maximum smoothed data number is  $30(\text{min}) / 2(\text{min}) = 15$

#### 4.8 Set / Check Working Status

**Set:**

Send: 11 02 51 [DF1] [CS]

Response: 16 01 51 [CS]

**Check:**

Send: 11 01 51 [CS]

Response: 16 02 51 [DF1] [CS]

**Description:**

DF1 = 0 single measurement mode (command A)

DF1 = 1 continuous measurement mode (command B)

**Example:**

Set to continuous power mode

Send: 11 01 51 01 98

#### 4.9 Sensor ABC Calibration Storing Data

Send: 11 01 11 [CS]

Response: 16 01 11 [CS]

Description: When the sensor is in the single measurement mode, the host will send an ABC calibration storing data command to the sensor every 30min(if power supply interval is less than 30min), or after each time measurement (if the power supply interval is longer than 30min).



# I<sup>2</sup>C Communication Protocol

## 1. I<sup>2</sup>C settings

The sensor acts as a slave device on the I<sup>2</sup>C bus.

Table 1: I<sup>2</sup>C settings

Parameter	Value	Description
Master/slave mode	Slave	Sensor will never initiate communication
Data rate	Up to 100kbit/s (standard mode)	
Addressing mode	7 bit	
Address range	2 – 126	An Even number, default address is 0X68 (address + writing bit) 0X69 is address + reading bit
Clock stretch	Yes	If sensor needs time to evaluate a received byte it will hold SCL low
SCL pull-up	10kΩ	
SDA pull-up	10kΩ	
SCL frequency	10kHz~400kHz	SCL frequency is generated by the master device
Writing time to EE	<25ms	Writing one register to sensors EEPROM can take up to 25ms, if sensor is powered down when EEPROM write operations are ongoing it may result in corrupt parameters.
Writing time to	<1ms	

**Note:**

Communication sequence:

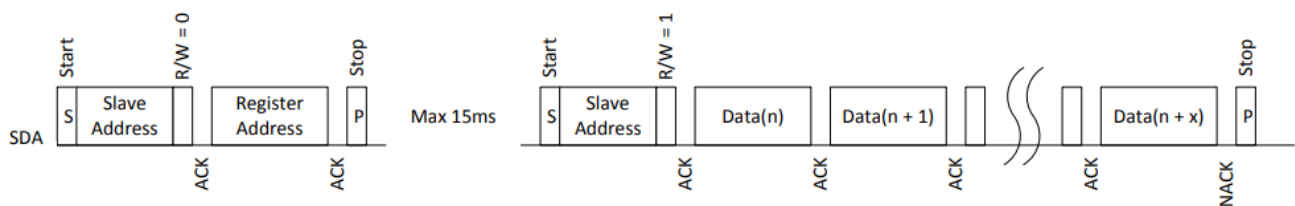

Figure 10. Reading from the sensor

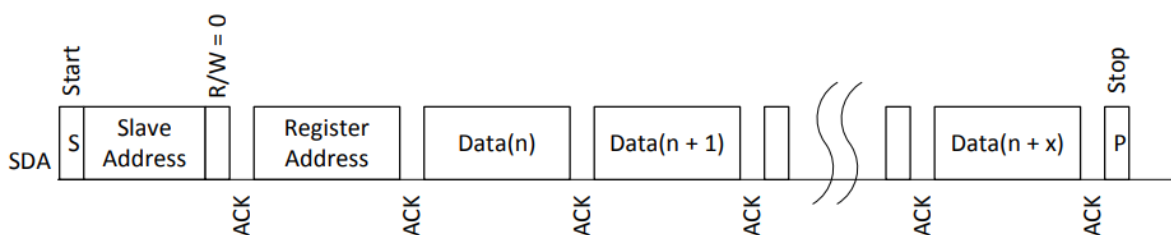

Figure 11. Writing to the sensor

## 2. I<sup>2</sup>C register map

I<sup>2</sup>C registers are categorized into two groups, which are Table 2 I<sup>2</sup>C read only registers and Table 3 I<sup>2</sup>C read/write registers.

Table 2: read only registers

Error Status	0X00	Reserved		
	0X01	Bit	Error description	Suggested action
		0	Fatal error Indicates that initialization of analog front end failed	Try to restart sensor by power on/off. Contact the supplier
		1~4	Reserved	
		5	Out of range Indicates that the measured concentration is outside the sensor's measurement range	Perform suitable CO2 calibration (zero, background or target calibration). Contact the supplier.
		6~7	Reserved	
Reserved	0X02~0X05			
CO2 concentration	0X06	0X06 is high byte and 0X07 is low byte, the unit is ppm, CO2 concentration=0X06*256+0X07		
	0X07			
Temperature	0X08	Chip temperature, T=0X08*256+0X09, unit °C x100. For example, register value = 2223 means 22.23°C.		
	0X09			
Reserved	0X0A~0X0C			
Measurement count	0X0D	Counter incremented after each measurement, range 0 – 255. The counter wraps around after the maximum value is reached.		
Measurement cycle time	0X0E	Measurement cycle time shows current time in present measurement cycle, incremented every 2 seconds. For example, Measurement cycle time = 3 means 6 seconds has passed in current measurement cycle. Value is set to 0 when sensor starts a new measurement.		
	0X0F			
CO2 concentration	0X10	0X10 is high byte and 0X11 is low byte, the unit is ppm, CO2 concentration=0X10*256+0X11		
	0X11			
CO2 concentration	0X12	0X12 is high byte and 0X13 is low byte, the unit is ppm, CO2 concentration=0X12*256+0X13		
	0X13			
CO2 concentration	0X14	0X14 is high byte and 0X15 is low byte, the unit is ppm, CO2 concentration=0X14*256+0X15		
	0X15			
Reserved	0X16~0X3F			

Table 3: read/write registers

Name	Register number / Address	Description (read only registers)	
Reserved	0X80		
Calibration Status	0X81	Bit	description
		0~2	Reserved
		3	ABC calibration
		4	Target calibration
		5	Background calibration
		6	Zero calibration
		7	Reserved
Calibration Command	0X82	Command	Name and description
		0X7C02~ 0X7C04	Reserved
		0X7C05	Target calibration.
	0X83	0X7C06	Background calibration
		0X7C07	Zero calibration.
Calibration Target	0X84	Calibration target used by target calibration (0X82...0X83- 0X7C05 command).	
	0X85		
CO2 Value Override	0X86	Default value = 32767 (no override). If a value lower than default is written to the register CO2 value will be 0x87 (LSB) set to this value after next measurement.	
	0X87		
ABC Time	0X88	Time passed since last ABC calibration in hours.	
	0X89		
Reserved	0X8A-0X92		
Start Single Measurement	0X93	Writing 1 initiates a measurement if the sensor is configured for single measurement mode.	
Reserved	0X94		
Measurement Mode (EE)	0x95	There are two measurement modes to choose between. Value = 0, continuous measurement mode. Value = 1, single measurement mode (default).	
Measurement Period (EE)	0X96	Measurement period in seconds (range from 2 to 65534). Odd numbers will be rounded up to nearest even number. Note: Measurement period is only used in continuous measurement mode	
	0X97		
Reserved	0X98~0X99		
ABC period (EE)	0X9A	Period for ABC cycle in hours (range from 24 to 240). Default is 168 hours. ABC cycle will be in the unit of day.	
	0X9B		
Reserved	0X9C~0X9D		

ABC Target (EE)	0X9E	Target value for background and ABC calibrations (ppm CO2). Default value is 400 (400 ppm CO2).	
	0X9F		
Reserved	0XA0~0XA4		
Meter control (EE)	0XA5	Bit	description
		0	reserved
		1	0: ABC enabled; 1: ABC disabled
		2~7	reserved
Reserved	0XA6		
MB/I <sup>2</sup> C address (EE)	0XA7	Sensor address, range 2 – 126 (0X02 – 0X7E). Default value is 104 (0x68). A sensor reset is needed to activate the new address. EEPROM mapped register. The address shall be an EVEN number otherwise the sensor will not response correctly and may cause IIC communication false.	
Reserved	0XA8~0XDF		

### 3. I<sup>2</sup>C Example on Cubic Testing Board

#### 3.1 Read measuring result:

Send: 68 06 00 02

No Response

Send: 69

Response: 04 EE

#### Note:

- 68 is address + writing bit, 06 is starting register to be read/write; 00 is reading command to Cubic testing board, and 02 is byte digit need to be read, for other device setting method might be different.
- The sensor will not response to the command "68 06 00 02".
- 69 is address + reading bit, to read measurement result.
- Response with 2 bytes 04 EE, CO<sub>2</sub> measuring result = (0x04 0xEE) hexadecimal = 1262 ppm.

#### 3.2 Set up continuous working mode

Send: 68 95 00 01 01

No Response

#### Note:

- 68 is address + writing bit, 95 is starting register to be read/write, 00 is the data to be written to register; the first 01 is writing command to Cubic testing board, and the second 01 is byte digit need to be written, for other device setting method might be different.
- The sensor will not response to the command "68 95 00 01 01".

## Packing Information

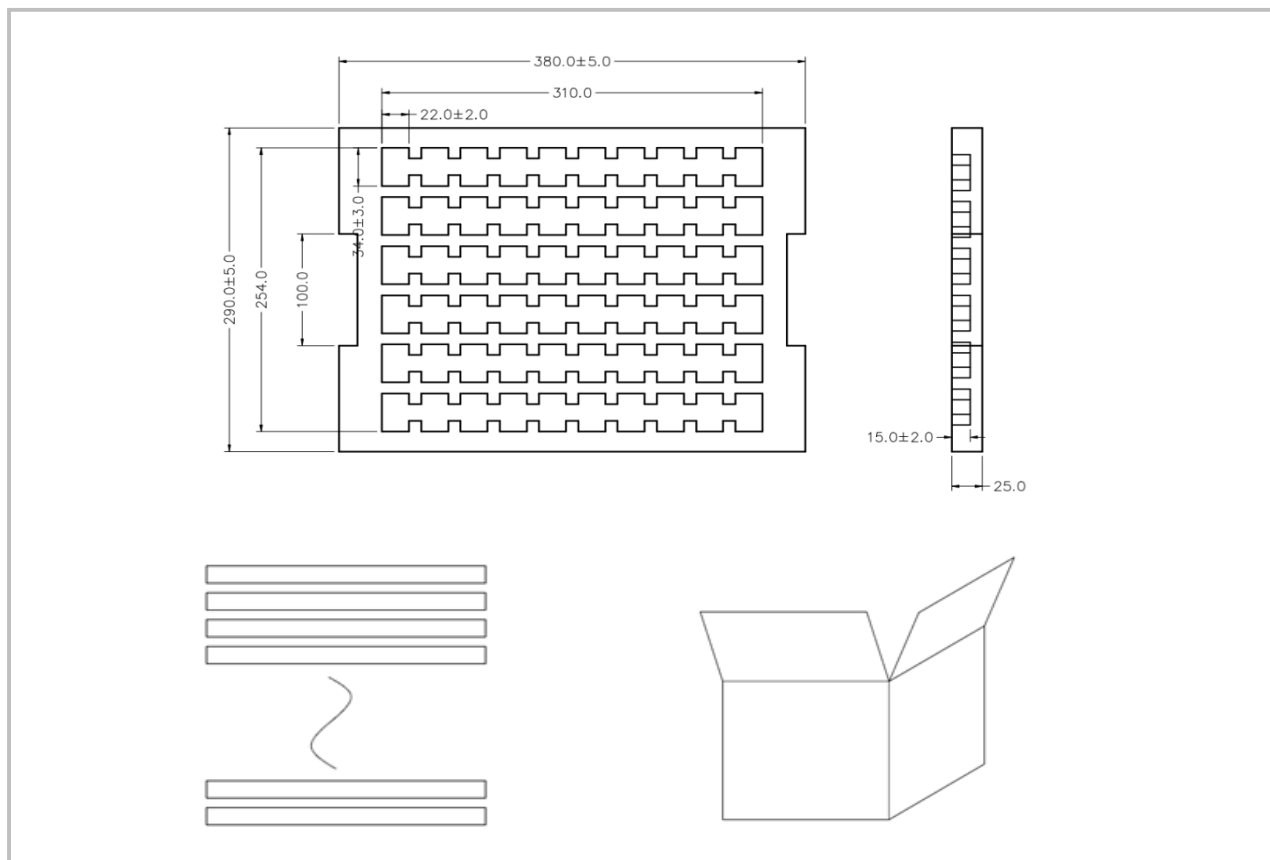

Sensor per Tray	Tray Qty	Sensor per Carton	Carton Dimensions	Packing Material
60 pcs	18 layers	1080 pcs	395*310*480 mm	Red anti-static EPE

## After-Sales Services and Consultancy

Cubic Sensor and Instrument Co.,Ltd

Tel: +86 (0)27 81628827 Fax: +86 (0)27 81628821

Add: Fenghuang No.3 Road, Fenghuang Industrial Park, Eastlake Hi-tech  
Development Zone, Wuhan 430205, China

E-mail: info@gassensor.com.cn